NoLoad TwinTran™
Installation & Configuration Guide

ML and SL Versions

TwinTran™ Installation & Configuration Guide

Copyright © 2007 Datacap Systems Inc. All rights reserved.

This manual and the hardware/software described in it are copyrighted materials with all rights reserved. Under copyright laws, the manual and the information contained in it may not be copied, in whole or in part, without written consent from Datacap Systems, Inc. Our policy of continuous development may cause the information and specifications contained herein to change without notice.

Datacap, Datacap Systems, TwinTran, DSIClient, ePay Administrator, WinPop, TwinTran, NoLoad (Patent Pending) TwinTran and DataTran are trademarks of the Datacap Systems Inc.

Microsoft, Windows NT 4.0, Windows 2000 Professional, Windows XP and Windows 98 are either trademarks or registered trademarks of the Microsoft Corporation.

Other products or company names mentioned herein may be the trademarks or registered trademarks of their respective companies.

Printed in the United States of America

Revised: 26 June 2007

Version Support

This document supports the following application versions:

Mercury Direct, Version 1.50 (or later)

CONTENTS

OVERVIEW	4
INTRODUCTION.....	4
<i>About NoLoad TwinTrans</i>	<i>4</i>
<i>About Datacap.....</i>	<i>4</i>
WHAT'S INCLUDED WITH YOUR NOLOAD TWINTRAN	4
HOW IT WORKS.....	5
INSTALLATION	7
REQUIREMENTS.....	7
<i>Communications Requirements</i>	<i>7</i>
INSTALLATION PROCEDURE	7
<i>Connecting the TwinTran with ML Application</i>	<i>7</i>
<i>Connecting the TwinTran with SL Application.....</i>	<i>9</i>
<i>IP Networking Considerations</i>	<i>11</i>
<i>Troubleshooting Resources for Networking Problems.....</i>	<i>11</i>
ACTIVATION & TESTING	12
ACTIVATION.....	12
TESTING	12
<i>Important! - Before You Start Live Processing</i>	<i>12</i>

OVERVIEW

Introduction

About NoLoad TwinTran

The *NoLoad TwinTran* is a direct replacement for a DataTran that processes transactions via the Internet processing without any merchant programming requirements. The *NoLoad TwinTran ML or SL* connects to the serial port of a POS system or ECR exactly as a DataTran. The TwinTran ML version is designed for multi-register LAN'd configurations; the SL version is designed for a single, standalone ECR/POS. Since a *NoLoad TwinTran* understands DataTran commands, it is a plug'n'play alternative to DataTran ML or SL. And since the supported payment processors use the unique MAC address encoded into each *NoLoad TwinTran* at the factory, it is not necessary to load merchant specific parameters into the TwinTran.

About Datacap

Datacap Systems, Inc. develops and markets electronic payment interfaces that enable cash register and business systems developers to add electronic payment acceptance to their systems.

Datacap has various solutions that interface to virtually any hardware or software platform and send transactions to all major payment processors via most common communications technologies including dial, wireless, and Internet.

What's Included with your NoLoad TwinTran

The *NoLoad TwinTran* system includes the following components in the shipping box:

- ***TwinTran (P/N: 1910.10)*** – The TwinTran unit with memory and power, Ethernet, telephone and three serial connectors.
- ***TwinTran Application*** - The *NoLoad TwinTran* has the software to support secure IP communications to Mercury Payment Systems installed at the factory. One of the following software part numbers will be labeled on the bottom of the TwinTran for identification as follows:
 - 9000.70** – Mercury ML version
 - 9000.75** – Mercury SL version
- ***Power Transformer*** – for use with 110V AC power.
- ***NoLoad TwinTran Installation Guide*** – This installation guide.
- ***Cables*** – Ethernet and Telephone cables and additional cables based on options described in following sections.

How it works

The *NoLoad TwinTran* is designed to allow ECR/POS systems that support the Datacap Serial Command Interface format commands (used by DataTran) to process transactions via IP with dial backup to supported payment processors. The ECR/POS system is connected to a *NoLoad TwinTran* via an RS232 interface. The *NoLoad TwinTran* is also connected via the Ethernet connector to a persistent IP connection with DHCP server and DNS services available and to a regular telephone line.

When the *NoLoad TwinTran* receives a transaction request from the ECR/POS system, it reformats, encrypts and transmits the message to a supported payment processor over the Internet. When the *NoLoad TwinTran* receives a response from the processor, it decrypts and reformats the response into DataTran format and sends it back to the ECR/POS over the serial connection. If the *NoLoad TwinTran* is unable to process the transaction over the Internet, it will attempt to use the regular phone line. If the secondary phone connection also fails, it will return an error message to the ECR/POS.

Every *NoLoad TwinTran* is manufactured with a unique MAC (Media Access Control) number to identify itself to the processing host at a supported payment processors. By contacting a supported payment processor to get a Merchant account established and providing the MAC value for the *NoLoad TwinTran* to be used at the merchant's location, no programming of the *TwinTran* hardware is required.

A typical configuration for a *NoLoad TwinTran with an ML application loaded* is as follows:

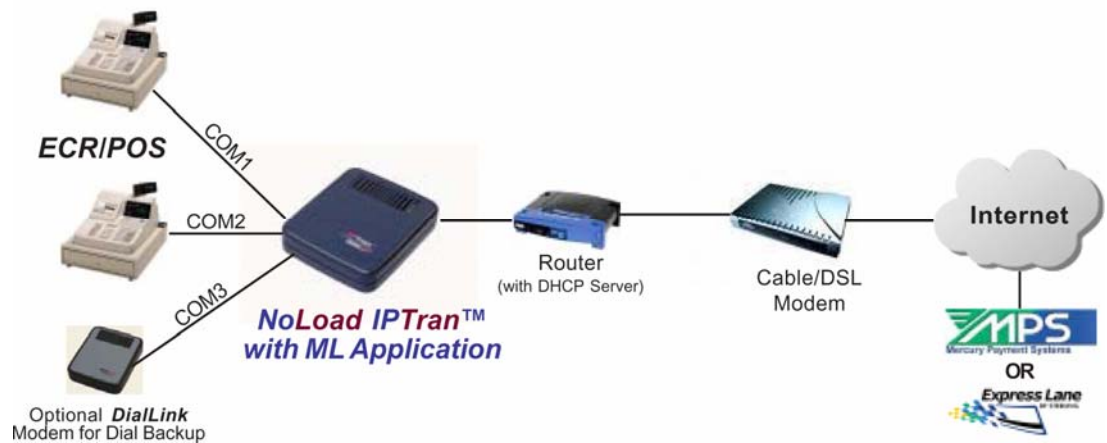

A typical configuration for a *NoLoad TwinTran with an SL application loaded* is as follows:

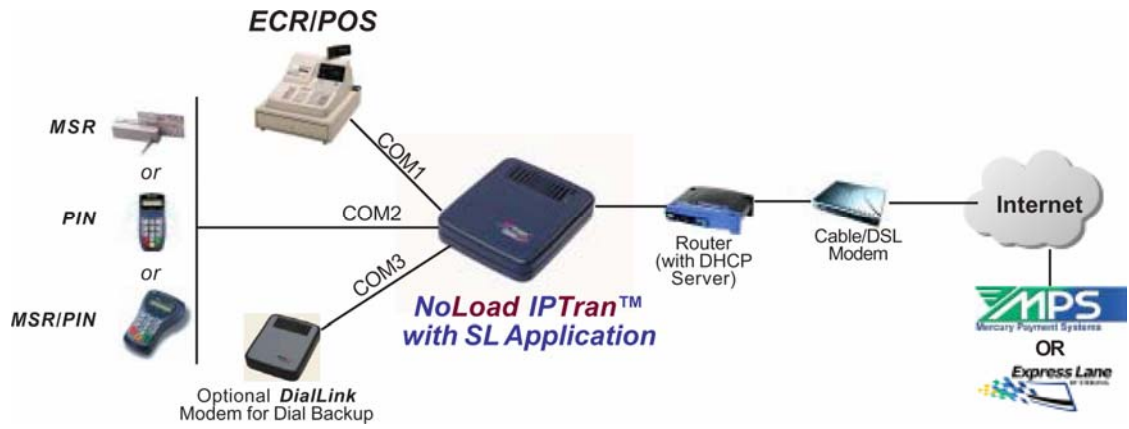

Note: Support for DialLink backup in both ML and SL will be available 3rd quarter 2007.

INSTALLATION

Requirements

Communications Requirements

To successfully install and run a *NoLoad TwinTran*, you should confirm that there are networking services available with the following characteristics:

- An Ethernet connection supporting TCP/IP network connectivity
- A persistent Internet connection; cable, DSL, dedicated line, frame relay, etc. Dial access that holds an open line will also work due to low bandwidth requirements.
- Active DHCP server availability. The *NoLoad TwinTran* obtains a dynamically assigned IP address from a DHCP server. The DHCP server should also provide the address of the gateway and the subnet mask.
- Access to Internet DNS (Domain Name Services).
- A regular phone line for dial backup operation.

Inexpensive routers which are widely available, such as Linksys, D-Link or Belkin, can provide the required DHCP and DNS services if properly configured.

Installation Procedure

Connecting the TwinTran with ML Application

Connect either COM1 or COM2 (or both) on the *NoLoad TwinTran* to the appropriate serial port on the ECR/POS system with the appropriate cable.

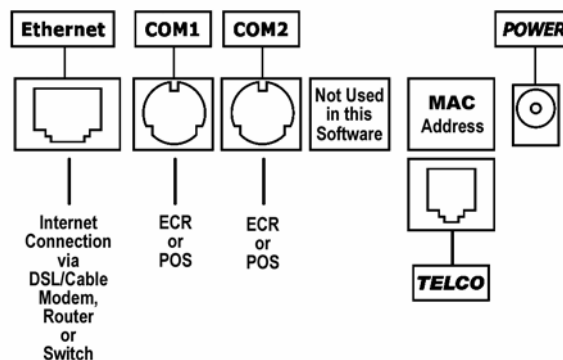

Cables for connecting ECR/POS devices to the *NoLoad TwinTran* are available from Datacap Systems Inc. The following cables are available:

Datacap Cable P/N	Required Adapter	Mfg	ECR Model
7871-00	7877.02	Sam4S Sharp Casio TEC Uniwell	1000, 2000 A410, A420, A520, A530, A570, A610, A770, UP600, UP700, UP3300, UP3301 QT2100, QT6000, ,QT7300, QT8000, TE2200, TE2400, TE3000, TE4500, TE8500 MA1535, MA1595 DX890, TX850, TX870, SX7000, SX8000
7871-01	7877.02	Sam4S	380, 390, 600, 650, 52XX, 7000
7871-10	7877.02	Sam4S	600, 1000, 2000, 7000
7871-10	7877.02	CRS	3000
7871-11	7877.02	CRS	4000

Note:

These ECR cables are identical to those used for the DataTran ML. In addition to the cables described above, an adapter (uDIN6M-uDIN8F - PN: 7877.02) must be used and is included and attached to the selected cable

Using an Ethernet cable, connect the *NoLoad TwinTran* Ethernet port to the Modem/Router/Switch in your network that provides DHCP and DNS services as outlined in the previous section.

Note:

TwinTran must be connected to a network with an active DHCP server so that it can acquire a non conflicting IP address. This is the principal cause for failure of NoLoad TwinTran to operate, so it should be verified as the first step in troubleshooting.

Connect the RJ phone cord to the TwinTran and to the telephone jack.

Connect the power to the *TwinTran* and verify that the red and green LEDs on the front of the *TwinTran* are illuminated within twenty seconds. If these LEDs do not light within that time, verify the network cable and status, disconnect the power and reconnect the power.

Note:

The red and green LEDs on the top front edge of the *TwinTran* must both be illuminated indicating that it's NIC (Network Interface Controller) is properly initialized. Although both LEDs are required for proper operation, they do not necessarily guarantee that your router/switch/modem have provided a legitimate IP address to TwinTran. See Activation and Testing to verify operation.

Connecting the TwinTran with SL Application

Connect COM1 on the *NoLoad TwinTran* to the appropriate serial port on the ECR/POS system with the appropriate cable.

Connect COM2 on the *NoLoad TwinTran* to one of the following optional devices: VeriFone 1000SE PIN pad, VeriFone SC5000 PIN pad with MSR or an IDT or Datacap MSR (see the cable chart below).

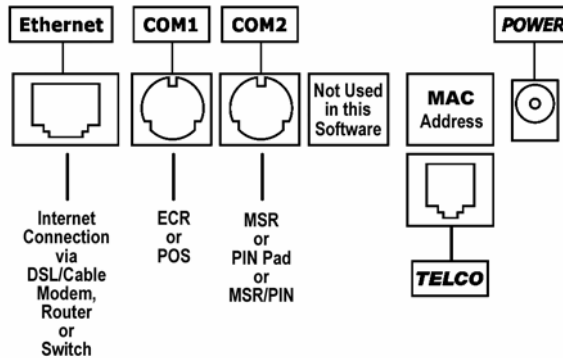

Cables for connecting ECR/POS devices to the *NoLoad TwinTran* are available from Datacap Systems Inc. The following cables are available:

Datacap Cable P/N	Required Adapter	Mfg	ECR Model
7871-00	7877.02	Sam4S Sharp Casio TEC Uniwell	1000, 2000 A410, A420, A520, A530, A570, A610, A770, UP600, UP700, UP3300, UP3301 QT2100, QT6000, ,QT7300, QT8000, TE2200, TE2400, TE3000, TE4500, TE8500 MA1535, MA1595 DX890, TX850, TX870, SX7000, SX8000
7871-01	7877.02	Sam4S	380, 390, 600, 650, 52XX, 7000
7871-10	7877.02	Sam4S	600, 1000, 2000, 7000
7871-10	7877.02	CRS	3000
7871-11	7877.02	CRS	4000

Note:

These ECR cables are identical to those used for the DataTran SL. In addition to the cables described above, an adapter (uDIN6M-uDIN8F - PN: 7877.02) must be used and is included and attached to the selected cable

Cables for connecting peripheral devices to the *NoLoad TwinTran* are available from Datacap Systems Inc. The following cables are available:

Peripheral P/N	Cable P/N	Required Adapter	Peripheral Device
7020.02	1332.10	7877.01	VFI 1000SE Pin Pad
7020.30	1332.10	7877.01	VFI SC5000 Pin Pad with MSR
7441.01	-	7877.00	Datacap MSR (RS232)
OEM	-	7877.00	IDT MSR (RS232)

Note:

These peripheral cables are identical to those used for the DataTran SL. In addition to the cables described above, an adapter must be used and is included and attached to the selected cable.

Using an Ethernet cable, connect the *NoLoad TwinTran* Ethernet port to the Modem/Router/Switch in your network that provides DHCP and DNS services as outlined in the previous section.

Note:

TwinTran must be connected to a network with an active DHCP server so that it can acquire a non conflicting IP address. This is the principal cause for failure of NoLoad TwinTran to operate, so it should be verified as the first step in troubleshooting.

Connect the RJ phone cord to the TwinTran and to the telephone jack.

Connect the power to the *TwinTran* and verify that the red and green LEDs on the front of the *TwinTran* are illuminated within twenty seconds. If these LEDs do not light within that time, verify the network cable and status, disconnect the power and reconnect the power.

Note:

The red and green LEDs on the top front edge of the *TwinTran* must both be illuminated indicating that it's NIC (Network Interface Controller) is properly initialized. Although both LEDs are required for proper operation, they do not necessarily guarantee that your router/switch/modem have provided a legitimate IP address to TwinTran. See Activation and Testing to verify operation.

IP Networking Considerations

The *NoLoad TwinTran* sends IP traffic to the Mercury server at one of the following URLs:

Mercury

X1.MERCURYPAY.COM
B2.BACKUPPAY.COM

The *NoLoad TwinTran* requires uninterrupted access to DNS services to resolve the IP addresses for these URLs for every transaction.

The *NoLoad TwinTran* sends the traffic to Mercury connecting to remote TCP port 9000.

Note:

It is important that any firewall hardware or software be properly configured to permit traffic to these URLs and ports.

Troubleshooting Resources for Networking Problems

Installation of the *NoLoad TwinTran* is usually a plug'n'play operation. When problems occur, the most frequent cause is some aspect of the LAN network configuration. Datacap has created a tool called the Datacap Setup Software (DSS) to assist in discovering and rectifying network problems with a *NoLoad TwinTran*. The DSS utility is free and you can download the DSS from Datacap's website (www.datacapsystems.com) – go to Support, then DataTran and locate the DSS download link.

Datacap also has another free test utility which can help an installer determine if a firewall or other LAN configuration is allowing access to any of the supported payment processors that NoLoad TwinTran can support. The utility is called Gateway Tester and is a free utility that you can download from Datacap's server at www.datacapipay.com.

ACTIVATION & TESTING

Activation

The *NoLoad TwinTran* is delivered with all internal software and settings loaded at the factory. Other than properly connecting *NoLoad TwinTran*, there are no other hardware or software setups.

You must have a pre-established merchant account with Mercury Payment Systems. You must also call Mercury with the MAC value of the *NoLoad TwinTran* to be used by that merchant. The MAC value for the TwinTran is located on a small label next to the Power connector.

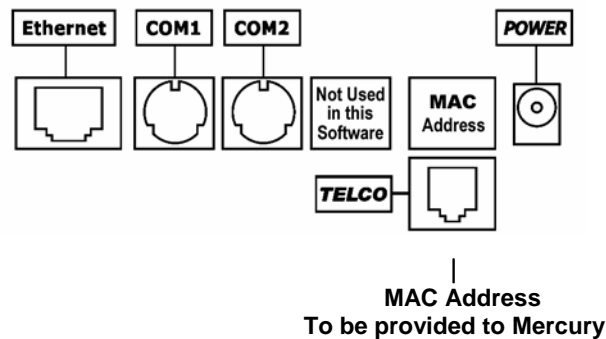

Call Mercury to activate the MAC address on their processing system for the merchant. Once the MAC has been activated, you can run test transactions to confirm proper operation. It is recommended that you perform a sale and refund of \$1.00 for each card type the merchant is entitled to accept. Then contact Mercury to verify that the transactions were properly processed.

Testing

Important! - Before You Start Live Processing

You should arrange with Mercury Payment Systems for testing *NoLoad TwinTran* and all other related components before going live.

It is the sole responsibility of the merchant account holder to verify that the merchant information created by Mercury is correct.

You should only process actual payments after verification that all test transactions have been successfully deposited.

Datacap Systems shall not be liable for any errors or for incidental or consequential damages in connection with the use of the software or other programmed information, including customer supplied or Datacap supplied information.